

SPECIFICATIONS

Type	Single-Sided 150mm Deep	
Where to fix	Wall Mounted	
LED Source	LED Modules SA 2398 Equivalent from SA-LED Australia	
Power Source	Suitable Power Supply from SA-LED Australia	
Dimension	Length	Any Size
	Height	Up to 1,500mm
	Deep	150mm
Face	4.5mm Opal Acrylic	
Return	Aluminum Extrusion Bar - Mill(2B) Finish - White or Black - 2Pac Spray (Other colours)	
Back	ACM or Equivalent Material	
Cover	25 / 40 / 50mm x 1.6mm Removable Angle Trim	

- Price do not include acrylic sheets.
- Price do not include packaging and delivery
- Artwork has to be provided by the client.
- Please make sure to include the original artwork files that is:

- ✓ 1:1 Scale
- ✓ PDF File format (*.pdf)
- ✓ 100% Vector(*.eps)
- ✓ CorelDRAW (*.cdr, *.dxf)

3D STRUCTURE

Front View

LEDs

Installed on the fabricated
ACM or Equivalent material

Return

Aluminum

Face

4.5mm
Opal Acrylic

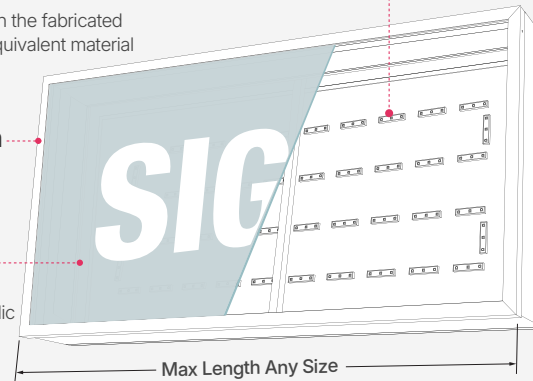

Side View

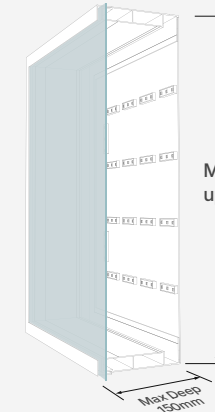

Side View : Wall Mounted

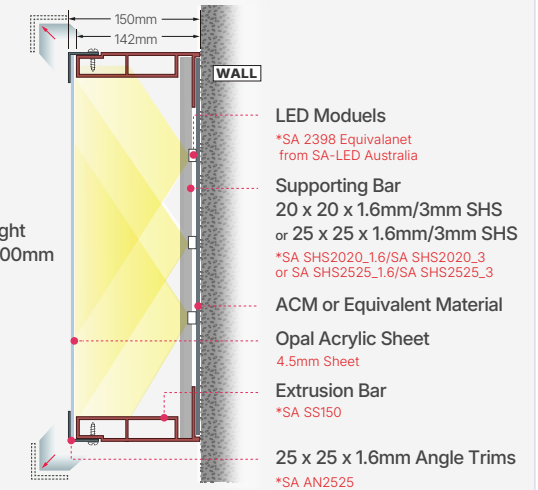

*All LED modules, power suppliers, extrusion bars, angle trims
and other bars can be purchased in www.SA-LED.com

INSTALLATION GUIDE

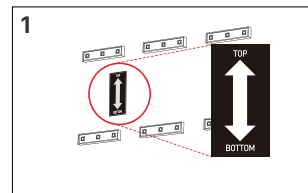

TOP & BOTTOM indicative sticker at the inside.

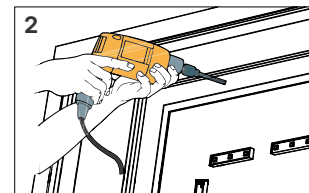

25x2mm perimeter fixing area for easy installation.

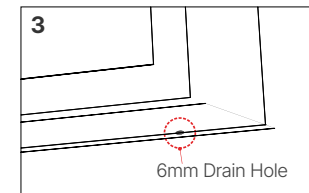

Predrilled 6mm drain holes on bottom.

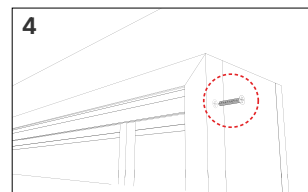

Remove screw from angle trims for insert acrylic.

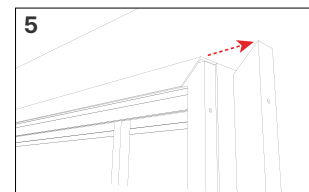

Remove angle trim from lightbox.

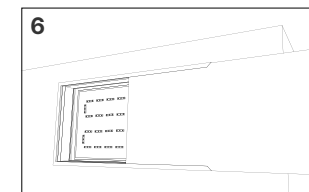

Insert acrylic face into body frame.

PROJECTS

